

불법복제 및 배포금지

1. LAYOUT DRAWING

Document No.
YJAT-5000L-ST5-AM

Rev.
0

Page
-

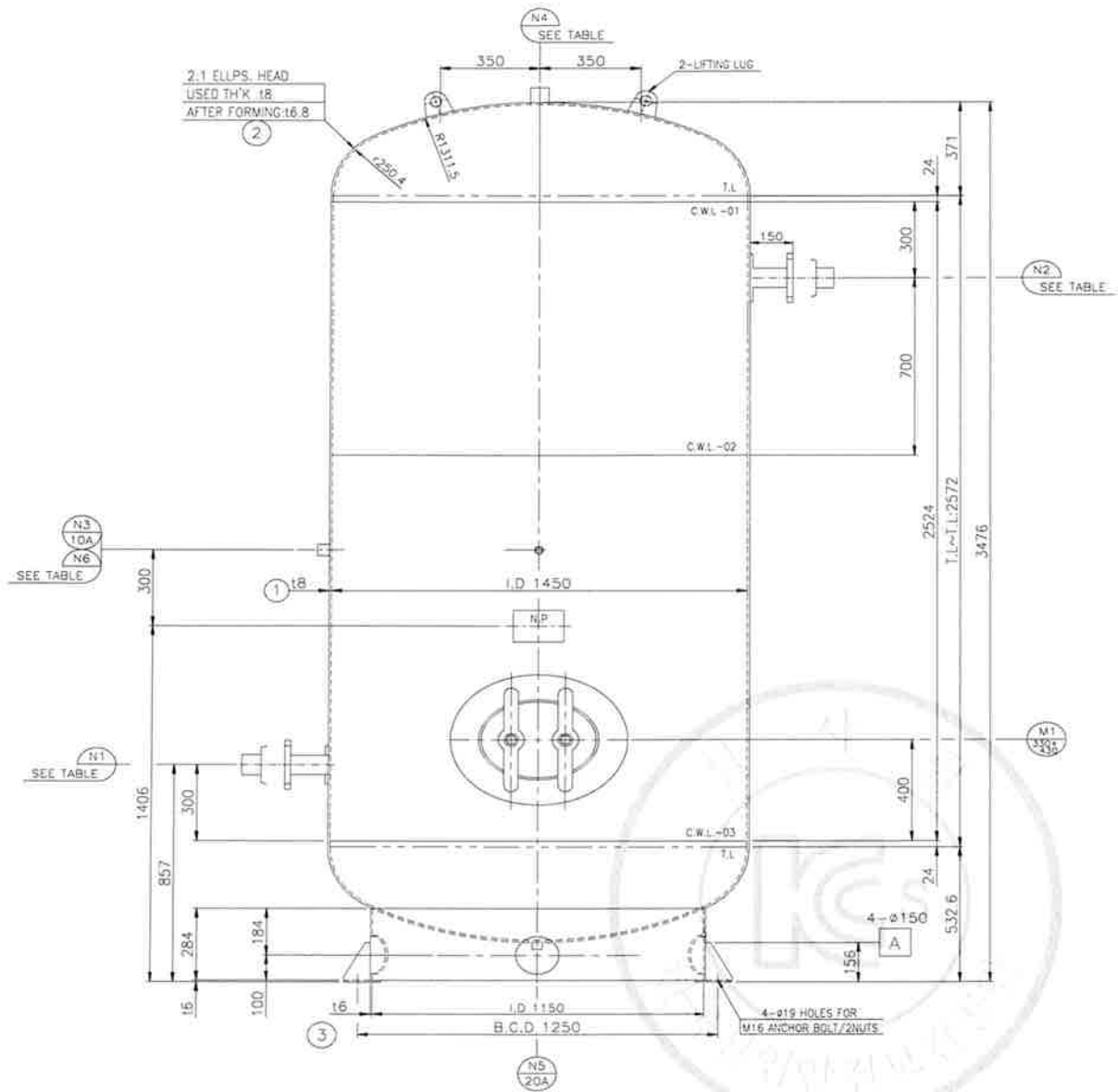

불법복제 및 배포금지

2. DESIGN CONDITION (설계조건)	Document No.	Rev.	Page
	YJAT-5000L-STS-AM	0	-

VOLUME : 5.0 m'

No.	DESCRIPTION	DESIGN DATA	참고사항
1	APPLICATION CODE(적용규격 코드)	ASME SEC.VIII, DIV.1	
2	VESSEL TYPE(압력용기 타입)	VERTICAL	
3	FLUID(사용유체)	AIR or N ₂	
4	DESIGN PRESSURE(설계압력)	INTERNAL 0.98 Mpa	
		EXTERNAL 0 Mpa	
5	OPER. PRESSURE(사용압력)	0.88 Mpa	
6	DESIGN TEMPERATURE(설계온도)	INTERNAL 100 °C	
		EXTERNAL - °C	
7	OPER. TEMPERATURE(사용온도)	INTERNAL AMB. °C	
8	HYDRO. TEST PRESSURE(수압시험 압력)	1.283 Mpa	
9	PNEU. TEST PRESSURE(공기압시험 압력)	N.A Mpa	
10	HEAD TYPE (경판형상)	2 : 1 ELLIPSOIDAL HEAD	
11	RADIOGRAPHIC EXAMINATION 비파괴 검사	SHELL : E1 LONGITU'L JOINT NO	
		SHELL : E2 CIRCUM'L JOINT NO	
		HEAD N.A	
12	JOINT EFFICIENCY (용접효율)	SHELL : E1 LONGITU'L JOINT 0.7	
		SHELL : E2 CIRCUM'L JOINT 0.7	
		HEAD 0.85	
13	PWHT [S / H/ H (S.R 처리)] (후열처리)	N.A / N.A / N.A	* S.R 처리 : Stress Reallies
	IMPACT & THERMAL LOAD, ETC	N/A	
14	CORROSION ALLOWANCE(부식여유)	0.0 mm	
15	SHELL INSIDE DIAMETER(동체내경)	1450 mm	
16	M. A. W. P.	NEW & COLD -	
		HOT & CORR. -	
17	LOCATION	INDOOR/OUTDOOR	
18	WEIGHT(무게)	ERECTION 1150 Kg	
		OPERATING(사용) 1150 Kg	
		FULL WATER(수압) 5150 Kg	
19	MATERIAL (재질)		
	- SHELL	STS304 137 N/mm ²	
	- HEAD	STS304 137 N/mm ²	
	- NOZZLE PIPE	STS304TP(W) 116 N/mm ²	
	- NOZZLE FLANGE	STS304 114 N/mm ²	
	- SUPPORT	SS400 114 N/mm ²	
	- EXT. BOLT /NUT	STS304/STS304 114 / 114 N/mm ²	
	- LIFTING LUG	SS400 114 N/mm ²	
- GASKET	NON-ASBESTOS -		

HYDRO. TEST PRESSURE: $P \times 1.3 \times \frac{138}{137} = 1.283 \text{ Mpa}$