

1. LAYOUT DRAWING	Document No.	Rev.	Page
	YJAT-10000L	0	-

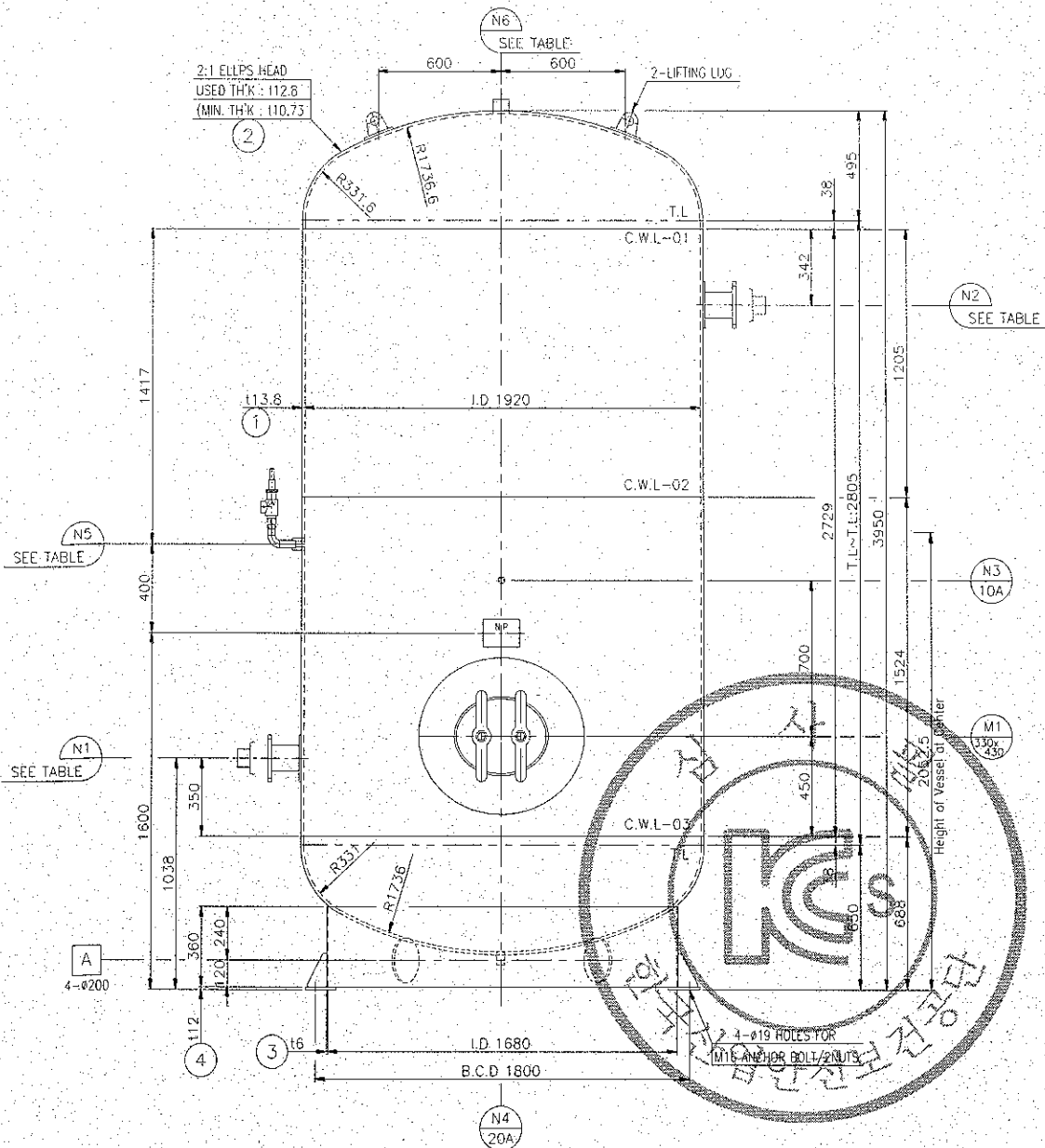

산업재해예방
안전보건공단

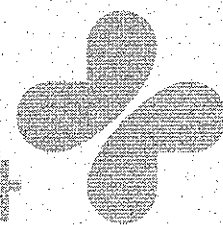

불법복제 및 배포금지

2. DESIGN CONDITION (설계조건)	Document No.	Rev.	Page
	YJAT-10000L	0	-

VOLUME : 10.0 m³

No.	DESCRIPTION	DESIGN DATA		참고사항
1	APPLICATION CODE(적용규격 코드)	KS B 6750&ISHL		
2	VESSEL TYPE(압력용기 타입)	VERTICAL		
3	FLUID(사용유체)	AIR or N ₂ or O ₂		
4	DESIGN PRESSURE(설계압력)	INTERNAL	0.98	Mpa
		EXTERNAL	0	Mpa
5	OPER. PRESSURE(사용압력)	0.88	Mpa	
6	DESIGN TEMPERATURE(설계온도)	INTERNAL	100	°C
		EXTERNAL	-	°C
7	OPER. TEMPERATURE(사용온도)	INTERNAL	AMB.	°C
8	HYDRO. TEST PRESSURE(수압시험 압력)	1.274	Mpa	
9	PNEU. TEST PRESSURE(공기압시험 압력)	N.A	Mpa	
10	HEAD TYPE (경판형상)	2 : 1 ELLIPSOIDAL HEAD		
11	RADIOGRAPHIC EXAMINATION 비파괴 검사	SHELL : E1	LONGITU'L JOINT	NO
		SHELL : E2	CIRCUM'L JOINT	NO
		HEAD		N.A
12	JOINT EFFICIENCY (용접효율)	SHELL : E1	LONGITU'L JOINT	0.7
		SHELL : E2	CIRCUM'L JOINT	0.7
		HEAD		0.85
13	PWHT [S / H / H (S.R 처리)] (후열처리)	N.A / N.A	N.A	S.R 처리 : Stress Reallies
	IMPACT & THERMAL LOAD, ETC	N/A		
14	CORROSION ALLOWANCE(부식여유)	1.0	mm	
15	SHELL INSIDE DIAMETER(통체내경)	1920	mm	
16	M. A. W. P.	NEW & COLD	-	
		HOT & CORR.	-	
17	LOCATION	INDOOR		
18	WEIGHT(무게)	ERECTION	2560	Kg
		OPERATING(사용)	2560	Kg
		FULL WATER(수압)	12540	Kg
19	MATERIAL (재질)			
	- SHELL	SS400	114	N/mm ²
	- HEAD	SS400	114	N/mm ²
	- NOZZLE PIPE	SPP(E)	61	N/mm ²
	- NOZZLE FLANGE	SS400	114	N/mm ²
	- SUPPORT	SS400	114	N/mm ²
	- EXT. BOLT /NUT	SNB7/S45C	130 / 122	N/mm ²
	- LIFTING LUG	SS400	114	N/mm ²
GASKET		NON-ASBESTOS		

HYDRO. TEST PRESSURE: $P \times 1.3 \times \frac{114}{114} = 1.274$ Mpa

안전보건공단