

1. LAYOUT DRAWING	Document No.	Rev.	Page
	YJAT-3000L	0	-

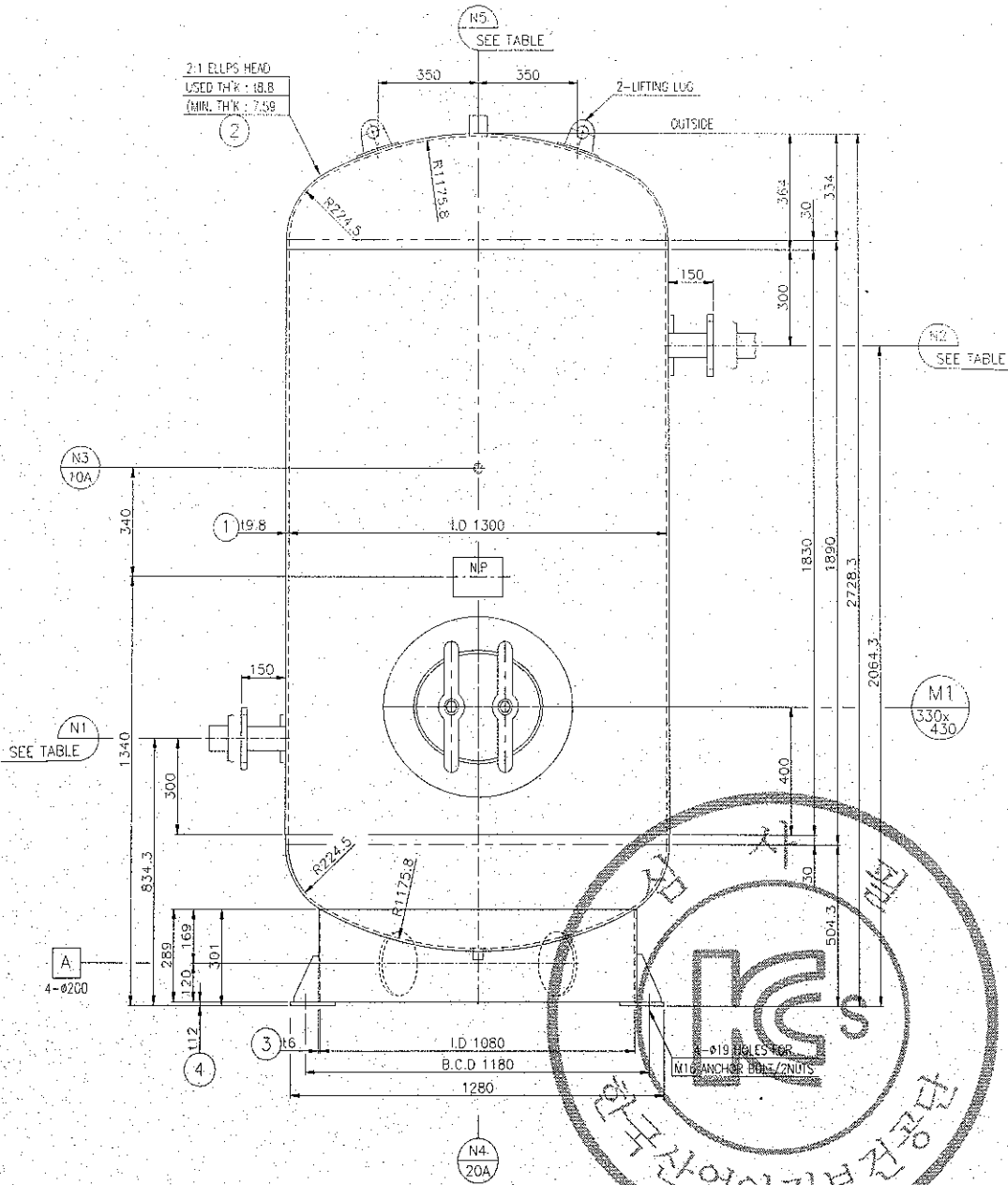

산업재해예방

안전보건공단

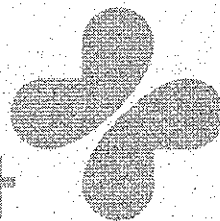

불법복제 및 배포금지

2. DESIGN CONDITION (설계조건)	Document No.	Rev.	Page
	YJAT-3000L	0	-

VOLUME : 3.1 m'

No.	DESCRIPTION	DESIGN DATA	참고사항
1	APPLICATION CODE(적용규격 코드)	KS B 6750&ISHL	
2	VESSEL TYPE(압력용기 타입)	VERTICAL	
3	FLUID(사용유체)	AIR or N ₂ or O ₂	
4	DESIGN PRESSURE(설계압력)	INTERNAL 0.98 Mpa	
		EXTERNAL 0 Mpa	
5	OPER. PRESSURE(사용압력)	0.88 Mpa	
6	DESIGN TEMPERATURE(설계온도)	INTERNAL 100 °C	
		EXTERNAL - °C	
7	OPER. TEMPERATURE(사용온도)	INTERNAL AMB. °C	
8	HYDRO. TEST PRESSURE(수압시험 압력)	1.274 Mpa	
9	PNEU. TEST PRESSURE(공기압시험 압력)	N.A Mpa	
10	HEAD TYPE (경판형상)	2 : 1 ELLIPSOIDAL HEAD	
11	RADIOGRAPHIC EXAMINATION 비파괴 검사	SHELL : E1 LONGITU'L JOINT NO	
		SHELL : E2 CIRCUM'L JOINT NO	
		HEAD N.A	
12	JOINT EFFICIENCY (용접효율)	SHELL : E1 LONGITU'L JOINT 0.7	
		SHELL : E2 CIRCUM'L JOINT 0.7	
		HEAD 0.85	
13	PWHT [S / H / H (S.R 처리)] (후열처리)	N.A / N.A N.A	S.R 처리 : Stress Realties
	IMPACT & THERMAL LOAD, ETC	N/A	
14	CORROSION ALLOWANCE(부식여유)	1.0 mm	
15	SHELL INSIDE DIAMETER(동체내경)	1300 mm	
16	M. A. W. P.	NEW & COLD -	
		HOT & CORR. -	
17	LOCATION	INDOOR	
18	WEIGHT(무게)	ERECTION 960 Kg	
		OPERATING(사용) 960 Kg	
		FULL WATER(수압) 4060 Kg	
19	MATERIAL (재질)		
	- SHELL	SS400 114 N/mm ²	
	- HEAD	SS400 114 N/mm ²	
	- NOZZLE PIPE	SPP(E) 61 N/mm ²	
	- NOZZLE FLANGE	SS400 114 N/mm ²	
	- SUPPORT	SS400 114 N/mm ²	
	- EXT. BOLT /NUT	SNB7/S45C 130 / 122 N/mm ²	
- LIFTING LUG	SS400 114 N/mm ²		
	GASKET	NON-ASBESTOS	

HYDRO. TEST PRESSURE: P x 1.3 x 114 = 1.274 Mpa

